

## WELS & Bath Installations:

Mixer is set up for basin installations with a 4 Star rating 7.0 l/m aerator.

For bath installations remove the 4 star rated aerator by unscrewing anti-clockwise and replace with flow straightener, using tool supplied.

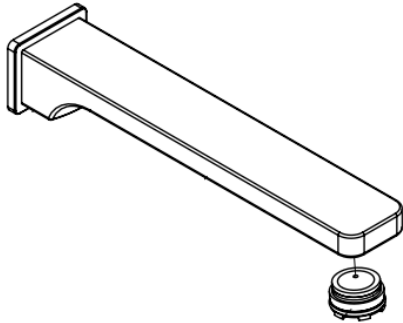

## ARCAS WALL BASIN / BATH MIXER (For Mains Pressure Installations Only) INSTALLATION INSTRUCTIONS

PRODUCT #

BATCH #

### ATTENTION PLUMBER

To ensure the optimum performance and customer satisfaction please adhere to the following:

- Flush out all pipe work prior to installation
- Installation shall be in accordance with the AS/NZS3500 series of standards.  
**The maximum operating pressure within any building should not exceed 500kpa.**  
Pressure above 500kpa can cause damage from water hammer, reducing life of appliances, taps and fittings and cause excessive noise in the plumbing system.
- Pressure over 500kPa will require a limiting valve.
- Inline strainer / filter must be installed in the line before the mixer to cover both hot and cold supplies (not supplied). Must be accessible.

### TECHNICAL DATA

- Minimum Water pressure for satisfactory operation: 150kPa
- Maximum Water pressure: 500kPa
- Maximum hot water temperature: 70°C  
If the Water temperature exceeds 70°C an approved Tempering Valve must be fitted.
- The flow rate of the sink and basin mixers has been rated under the NZ Water Efficiency Labeling Scheme (WELS).

Please leave this form with the product once installed.

For full warranty terms and conditions, please see the warranty card enclosed with this product or visit [www.greenstapware.com/warranty-and-care/](http://www.greenstapware.com/warranty-and-care/)

### NZ

**Distributed by: Greens Global Limited**

PO Box 5055, Hamilton, 3200

22 The Boulevard, Te Rapa, Hamilton 3200

Phone: 07 849 0109, Fax: 07 849 0540

Website: [www.greenstapware.com](http://www.greenstapware.com)

Email: [nzsales@greenstapware.com](mailto:nzsales@greenstapware.com)

**Service Hotline: 0800 655 455**

#42126 09/21

**NOTE: Valve body mounting 44-69mm behind finished wall  
 Finished wall cut-out: Mixer 42-45mm dia round.  
 Spout 25mm dia.**

**Installing Mixer Valve Body:**

1. **15mm Male** inlets & outlet.
  - a. Hot inlet (left), Cold inlet (Right).
  - b. Outlet (Top).
2. **44mm - 69mm back of valve body to the finished wall.**
3. Finished wall cut-out : **Mixer 42-45mm dia round, Spout 25mm.**
4. Do not pressure test with valve in the open position when the outlet is closed.

**Installing Bracket Elbow For Spout (not supplied):**

1. Install a brass 15mm male wingback elbow for spout position and connect water supply from mixer outlet to elbow.
  - a. Drawing 110mm (REF) is for guide only.
  - b. **Check alignment of body and wall elbow.**
  - c. Note: Must have **MAX 15mm of thread** from finished wall for adaptor.
2. Plug off elbow for water test.
3. Turn on water supply on and check for leaks.

**Install Face Plate & Handle:**

1. Remove the mud guard by removing screw.
2. Push on sleeve, screw on cover cap.
3. Remove protective tape from the seal. Position plate against wall with drain hole at the bottom.
  - a. Sealant will be required behind faceplate on uneven surfaces for water seal.
4. Install handle with the 2.5mm Allen key supplied and fit button.

**Installing Spout & Mounting Adaptor:**

1. Cut out mounting hole in finished wall for **spout 25mm** as per drawing.
2. Cut inlet thread to length,
  - a. **MAX 15mm thread from finished wall.**
3. Remove the mounting adaptor from spout by unscrewing the grub screws under the spout until nearly out.
  - a. This is to ensure the O-rings on the adaptor are not cut.
4. Install the female mounting adaptor.
  - a. Use a spanner or 10mm Allen key.
5. Grease O-rings, install spout ensuring seal is in place and tighten grub screws.

