

WELS:

To achieve the WELS star rating, remove the spray hand piece by unscrewing the hose and replace with the WELS restrictor / non return valve. Ensure washer is in place between hose and hand piece.

ADJUSTING FLOW LIMITER:

A flow limiter is fitted to this mixer to limit the flow of water in high pressure situations.

1. Remove handle by loosening grub screw through access hole under the handle button with a 2.5mm Allen key.
2. Turn mixer on full and wind in grub screw clockwise to achieve desired flow rate.
3. Replace handle.

ADJUSTING ANTI-SCALD RING:

An anti-scald ring is fitted to this mixer to limit the maximum movement of the handle when turned to the "HOT" position.

Ex factory the cartridge is set to the maximum HOT water flow.

1. Remove handle by loosening grub screw through access hole under the handle button with a 2.5mm Allen key. Unscrew cover sleeve.
2. Lift the red anti-scald ring sufficiently to disengage. Turn anti-clockwise and replace until the desired maximum temperature is obtained. Each notch on the ring gives a temperature change of approximately 2°C.
3. Replace cover sleeve and handle.



MARKETTI BLADE PULL-OUT SINK MIXER (For Mains Pressure Installations Only) INSTALLATION INSTRUCTIONS

PRODUCT #
160208900

BATCH #
180320

ATTENTION PLUMBER

To ensure the optimum performance and customer satisfaction please adhere to the following:

- Flush out all pipe work prior to installation
- Installation shall be in accordance with the AS/NZS3500 series of standards.
The maximum operating pressure within any building should not exceed 500kpa. Pressure above 500kpa can cause damage from water hammer, reducing life of appliances, taps and fittings and cause excessive noise in the plumbing system.
- Pressure over 1000kPa will require a limiting valve.
- Inline filters must be installed on both hot and cold supplies.

TECHNICAL DATA

- Minimum Water pressure for satisfactory operation: 150kPa
- Maximum Water pressure: 1000KPa
- Maximum hot water temperature: 70°C
If the Water temperature exceeds 70°C an approved Tempering Valve must be fitted.
- The flow rate of the sink and basin mixers has been rated under the NZ Water Efficiency Labeling Scheme (WELS).

Please leave this form with the product once installed.

For full warranty terms and conditions, please see the warranty card enclosed with this product or visit www.greenstapware.com/warranty-and-care/

Distributed by: Greens Global Limited
PO Box 5055, Hamilton, 3200
22 The Boulevard, Te Rapa, Hamilton 3200
Phone: 07 849 0109, Fax: 07 849 0540
Website: www.greenstapware.com
Email: nzsales@greenstapware.com
Service Hotline: 0800 655 455

INSTALLATION INSTRUCTIONS PULL-OUT SPRAY SINK MIXER

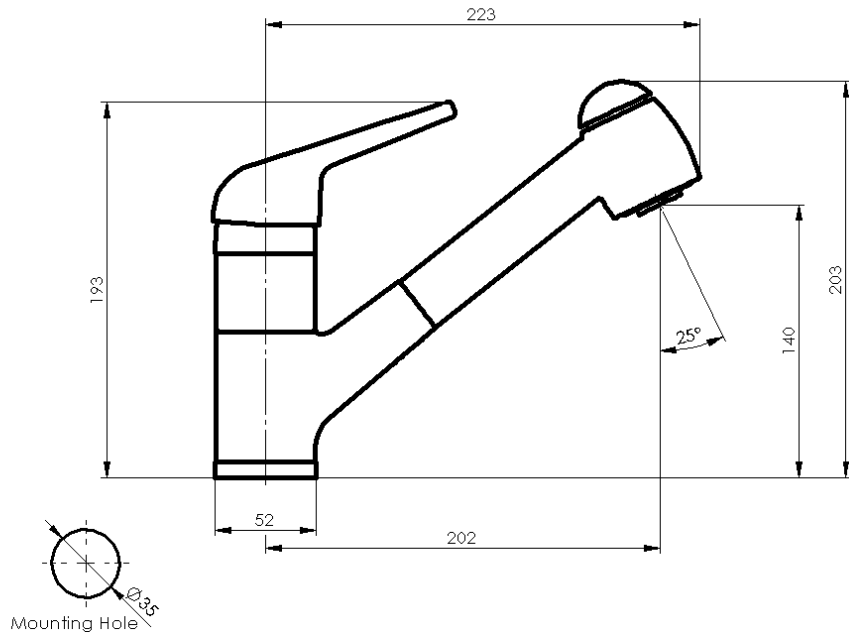

BENCH TOPS

- ◆ Formica/wooden bench tops, extra mounting support is required below the bench.
- ◆ Stainless steel bench tops ensure the mounting washer is against the S/Steel.
- ◆ **Vitreous china tops additional sealant maybe required at the base of the mixer to ensure a water tight seal.**

Note: Fits Maximum Bench thickness of 43mm.

To install mixer, cut a mounting hole 35mm in diameter in the bench surface.

1. Unscrew mounting nut and remove steel washer and rubber washer from threaded mixer tail. Ensure seal is sitting in groove at base of mixer.
2. Lower mixer into bench top with hose.
3. From underneath the bench install the rubber washer then steel washer and mounting nut over hose, copper pipes and screw mounting nut onto threaded tail of mixer. Position mixer and tighten the jacking screws.
 - a. **The outlet pipe with the swivel nut should be to the rear of the bench.**
 - b. Screws may require backing off before installing nut.
4. Connect pull-out hose to mixer outlet:
 - a. Check double check valve assembly is tight on the hose.
 - b. Connect the double check valve assembly that is attached to the hose to the outlet pipe, and ensure the **sealing washer** is in place by turning the swivel nut on the copper tail rather than the hose.
5. Connect the water supply to the mixer inlet tubes using adaptors supplied.
 - a. Hot inlet indicated with red tape indicator.
 - b. **Ensure that the copper tail pipes do not foul the travel of the hose.**
6. Install hand piece and weight.
 - a. Hand tighten the hand piece to hose and ensure the **rubber washer** is in place.
 - b. Install counter weight to hose (see drawing) and secure with the 2 screws.
7. Check travel of handset and reposition counter weight if necessary.
 - a. Inlet pipes do not foul the travel of the hose.
 - b. Hose and weight movement is free, the hose hangs in a loop and is not twisted.
8. Turn on water supply, **check for leaks** and check the operation of the hand piece.

