

INSTALLATION INSTRUCTIONS

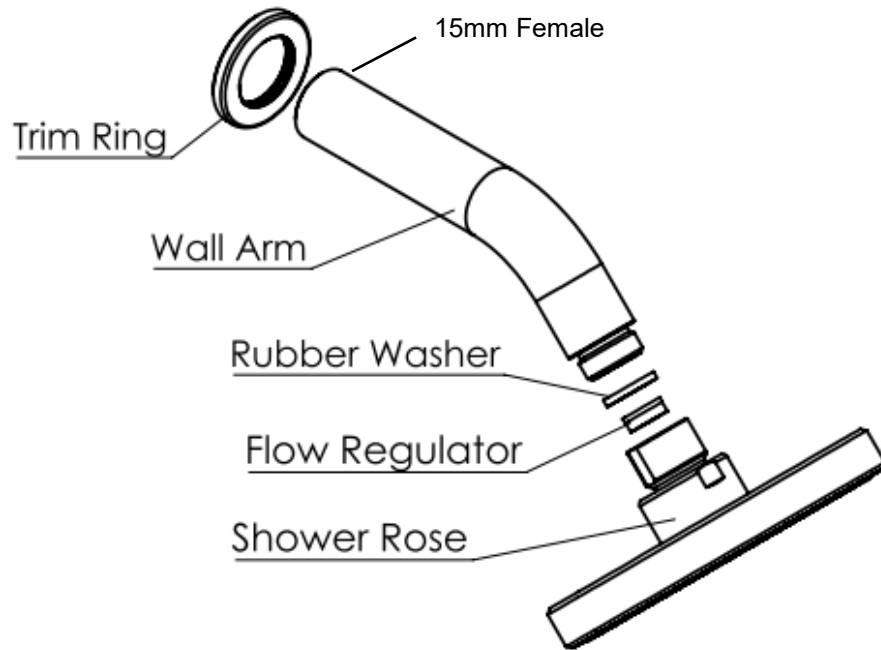

1. Carefully position trim ring to the wall arm and remove the protective tape from seal on trim ring.
 - a. Grease seal inside trim for ease of install.
2. Install shower arm to 15mm male parallel thread (not supplied) and position the trim ring against the wall lining.
 - a. Cut the inlet thread to a **MIN 10mm thread** from finished wall.
 - b. Additional sealant will be required for uneven surfaces for water seal.
3. Install overhead to arm and ensure washer seal is in place.

WELS – Mains pressure only

To achieve the 3 star 9.0 l/m rating install the WELS 3 star restrictor.

1. Remove the overhead rose from arm by unscrewing anti-clockwise.
2. Remove the washer seal in rose head .
3. Install the restrictor inside as shown above.
 - a. Will only go in one way, the narrow end first.
4. Replace washer seal and install rose head back onto the arm.



GLIDE RainBoost® WALL SHOWER

(For All Pressure Installations)

INSTALLATION INSTRUCTIONS

PRODUCT #

571000

BATCH #

231120

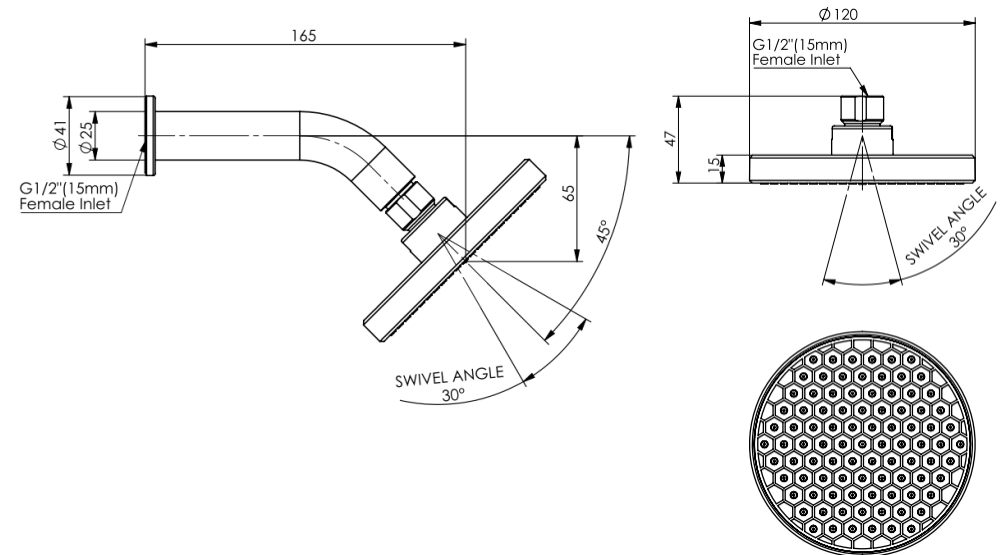

Technical Data:

- Suitable for use with high, low and unequal pressure supply networks.
- **Low Pressure: Recommend to be installed with a FloBOOST shower mixer.**
- **Unequal Low Pressure:**

- Minimum hot water pressure (Only with a FloBOOST). 10Kpa (flow pressure)
- Minimum cold water pressure (Only with a FloBOOST). 200kpa (flow pressure)
- Maximum cold water pressure. 500kpa

Equal Pressure - Low & Mains:

- Minimum water pressure. 20kpa (flow Pressure)
- Maximum Water pressure. 500kpa

- Pressure over 500kpa will require a limiting valve.
- Installation shall be in accordance with the AS/NZS3500 series of standards.

Distributed by: Greens Global Limited

PO Box 5055, Hamilton, 3200
 22 The Boulevard, Te Rapa, Hamilton 3200
 Phone: 07 849 0109, Fax: 07 849 0540
 Website: www.greenstapware.com
 Email: nzsales@greenstapware.com
Service Hotline: 0800 655 455

INSTALLATION INSTRUCTIONS

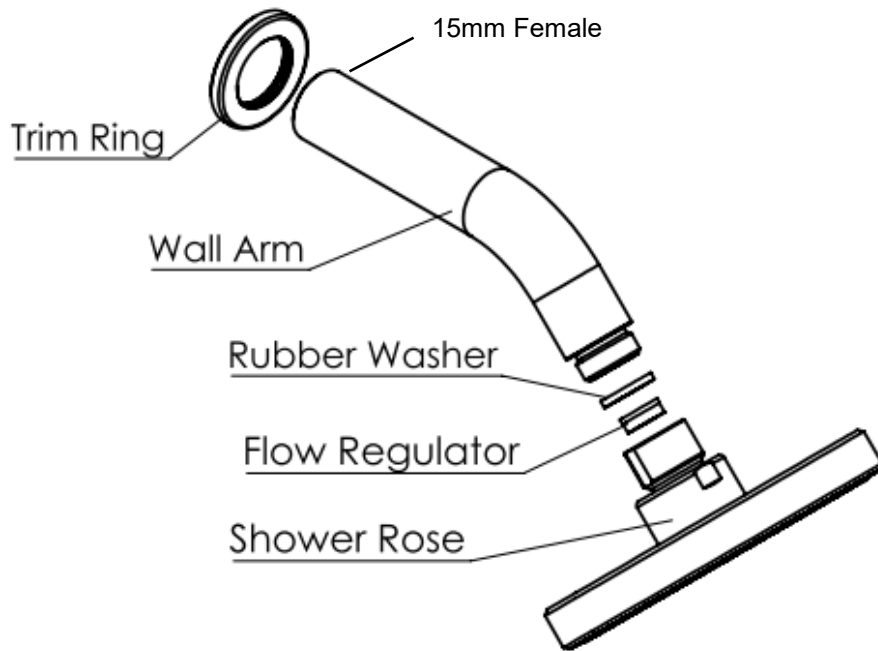

- Carefully position trim ring to the wall arm and remove the protective tape from seal on trim ring.
 - Grease seal inside trim for ease of install.
- Install shower arm to 15mm male parallel thread (not supplied) and position the trim ring against the wall lining.
 - Cut the inlet thread to a **MIN 10mm thread** from finished wall.
 - Additional sealant will be required for uneven surfaces for water seal.
- Install overhead to arm and ensure washer seal is in place.

WELS – Mains pressure only

To achieve the 3 star 9.0 l/m rating install the WELS 3 star restrictor.

- Remove the overhead rose from arm by unscrewing anti-clockwise.
- Remove the washer seal in rose head .
- Install the restrictor inside as shown above.
 - Will only go in one way, the narrow end first.
- Replace washer seal and install rose head back onto the arm.



GLIDE RainBoost® WALL SHOWER

(For All Pressure Installations)

INSTALLATION INSTRUCTIONS

PRODUCT #

571000

BATCH #

231120

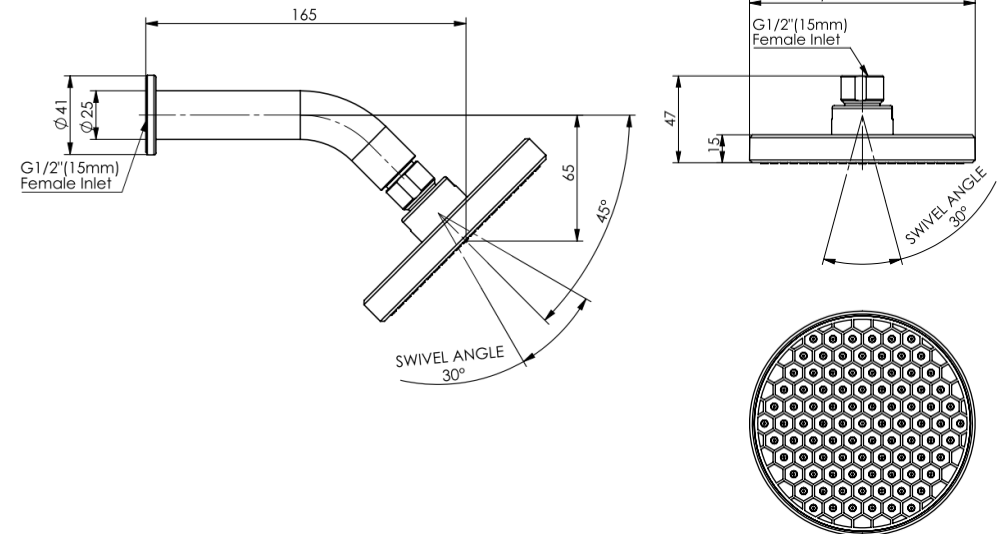

Technical Data:

- Suitable for use with high, low and unequal pressure supply networks.
- **Low Pressure: Recommend to be installed with a FloBOOST shower mixer.**
- **Unequal Low Pressure:**
 - Minimum hot water pressure (Only with a FloBOOST). 10Kpa (flow pressure)
 - Minimum cold water pressure (Only with a FloBOOST). 200kpa (flow pressure)
 - Maximum cold water pressure. 500kpa
- **Equal Pressure - Low & Mains:**
 - Minimum water pressure. 20kpa (flow Pressure)
 - Maximum Water pressure. 500kpa
- Pressure over 500kpa will require a limiting valve.
- Installation shall be in accordance with the AS/NZS3500 series of standards.

Distributed by: Greens Global Limited

PO Box 5055, Hamilton, 3200
 22 The Boulevard, Te Rapa, Hamilton 3200
 Phone: 07 849 0109, Fax: 07 849 0540
 Website: www.greenstapware.com
 Email: nzsales@greenstapware.com
 Service Hotline: 0800 655 455