



# TEXTURA & TESORA SHOWER/BATH DIVERTER MIXER (For Mains Pressure Installations Only) INSTALLATION INSTRUCTIONS

<b>PRODUCT #</b>
------------------

<b>BATCH #</b>
----------------

## ATTENTION PLUMBER

To ensure the optimum performance and customer satisfaction please adhere to the following:

- **Flush out all pipe work prior to installation.**
- Installation shall be in accordance with the AS/NZS3500 series of standards.  
**The maximum operating pressure within any building should not exceed 500kpa.**  
Pressure above 500kpa can cause damage from water hammer, reducing life of appliances, taps and fittings and cause excessive noise in the plumbing system.
- Pressure over 500kPa will require a limiting valve.
- Inline strainer / filter must be installed in the line before the mixer to cover both hot and cold supplies (not supplied). Must be accessible.

## TECHNICAL DATA

- **Suitable for use with high pressure water supply only.**  
Not suitable for gravity-fed water heaters, low and unequal pressure networks.
- Minimum Water pressure for satisfactory operation: 150kPa
- Maximum Water pressure: 500kPa
- Maximum hot water temperature: 70°C  
If the Water temperature exceeds 70°C an approved Tempering Valve must be fitted.

Please leave this form with the product once installed.

For full warranty terms and conditions, please see the warranty card enclosed with this product or visit [www.greenstapware.com/warranty-and-care/](http://www.greenstapware.com/warranty-and-care/)

Please contact country of purchase.

### NZ

**Distributed by: Greens Global Limited**  
PO Box 5055, Hamilton, 3200  
22 The Boulevard, Te Rapa, Hamilton 3200  
Phone: 07 849 0109, Fax: 07 849 0540  
Website: [www.greenstapware.com](http://www.greenstapware.com)  
Email: [nzsales@greenstapware.com](mailto:nzsales@greenstapware.com)  
**Service Hotline: 0800 655 455**

**Distributed by: Greens Global AUS PTY LTD**  
36 Naxos Way, Keysborough VIC 3173  
Phone: 1800 244 487 Fax: 1800 244 212  
Email: [aussales@greenstapware.com](mailto:aussales@greenstapware.com)  
Website: [www.greenstapware.com](http://www.greenstapware.com)  
**Service Hotline: 1800 244 992**

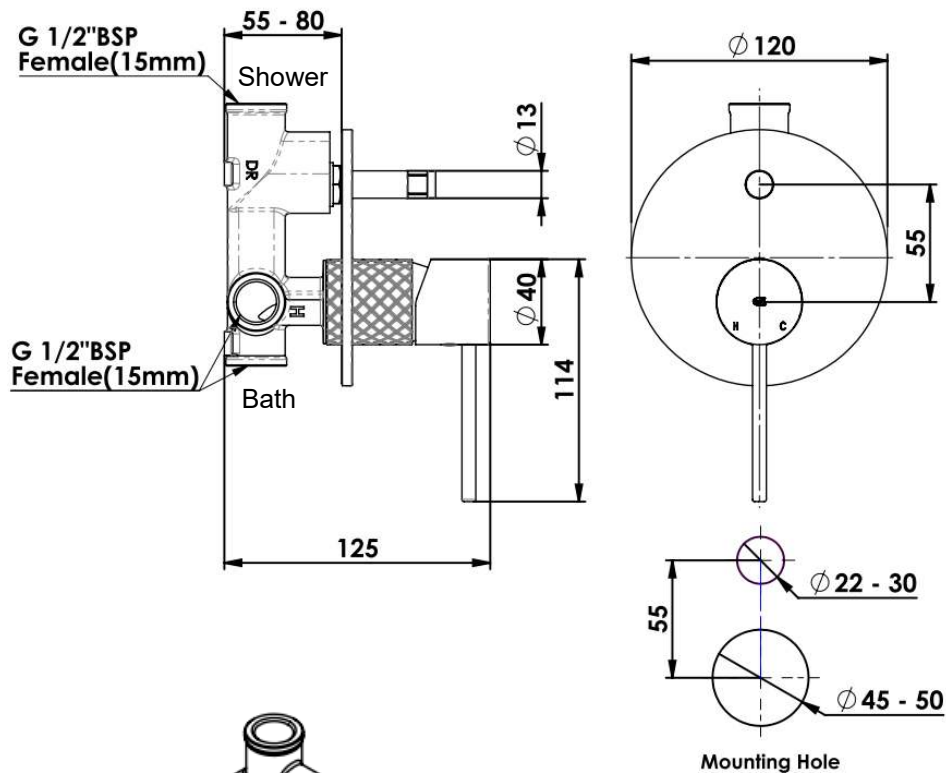

## INSTALLATION INSTRUCTIONS

### NOTE:

- **Valve body mounting 55-80mm behind finished wall.**
- **Multi function handsets min operating pressure 250kPa.**
- **Rail Shower Installations:** Non return valve to be fitted to the shower wall elbow outlet (not supplied).
- **Testing Valve Operation:** Must have a rose / handset connected

### Installing Valve Body:

1. Position the mixer against a mounting board within the **maximum and minimum depth of 55-80mm** and fix.
  - a. Mug guard has minimum and maximum for finished wall.
  - b. Ensure the **valve body is parallel** to the wall with the **diverter button at the top** above the handle as shown.
2. Connect water supply to the mixer and from the mixer to the outlets.
  - a. "Hot "(H) inlet inters on the left and "cold "(C) inlet is on the right.
  - b. **Top outlet is for the shower and the bottom outlet for the bath.**
    - i. Leave mud guards on valve body until final fit out.
  - c. **Do not pressure test with valve in the open position when the outlet is closed.**
  - d. Turn on water supply to the mixer and **check for leaks.**
3. Cut-out **hole in the wall lining for the mixer** as per drawing, and fix lining in place.
  - a. Body 45-50mm.
  - b. Diverter 22-30mm.

### Install Trim Set:

1. Remove the mud guards.
2. Position faceplate over the mixer body and against the wall lining.
  - a. Remove the protective tape from the seal.
  - b. Sealant will be required behind faceplate on uneven surfaces for water seal.
3. Install the handle onto the cartridge lever and tighten the screw under the handle with the 2.5mm Allen key supplied and fit button.
4. Screw on the diverter button.

