

INSTALLATION INSTRUCTIONS

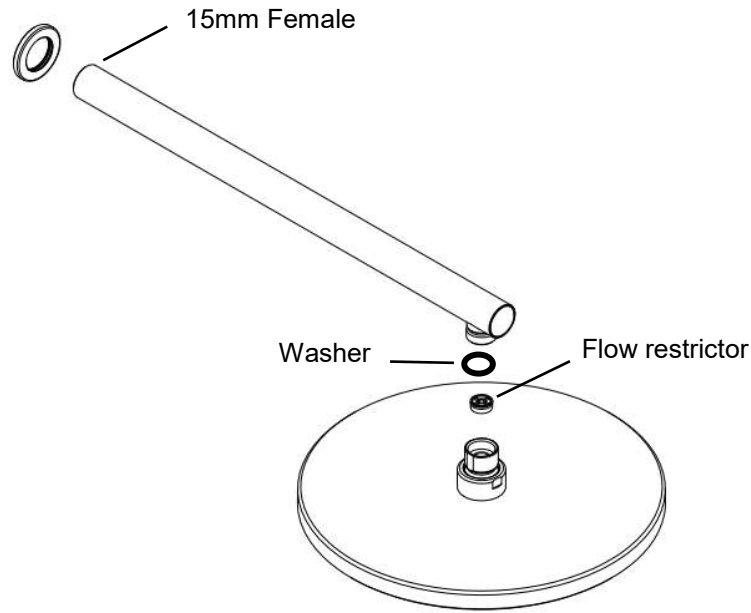

1. Position trim ring over the wall arm and remove the protective tape from seal on trim ring.
2. Install shower arm to 15mm male parallel thread (not supplied) and position the trim ring against the wall lining.
 - a. Max 15mm thread from finished wall.
 - b. Additional sealant may be required for uneven surfaces.
3. Install overhead to arm and ensure washer seal is in place.

WELS – Mains pressure only

To achieve the 3 star 9.0 l/m rating install the WELS 3 star restrictor.

1. Remove the overhead rose from arm by unscrewing anti-clockwise.
2. Remove the washer seal in rose head .
3. Install the restrictor inside as shown above.
 - a. Will only go in one way, the narrow end first.
4. Replace washer seal and install rose head back onto the arm.

GLIDE RainBoost® OVERHEAD WALL SHOWER

(All Pressure Installations)
INSTALLATION INSTRUCTIONS

PRODUCT #
573009

BATCH #
120820

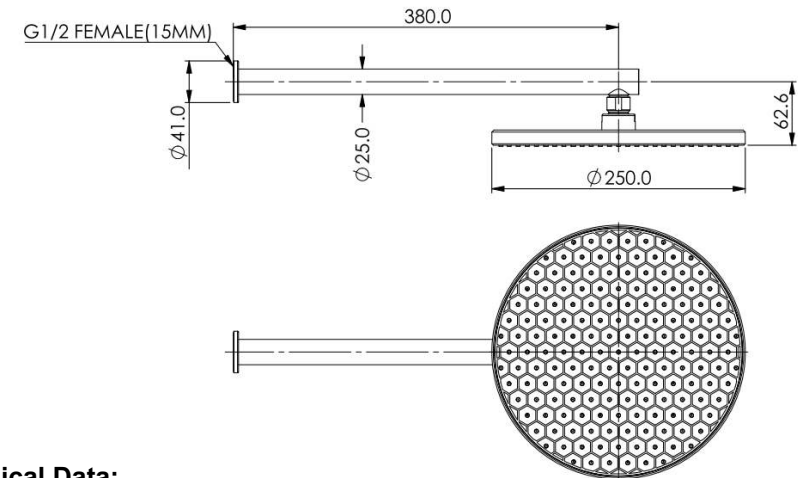

Technical Data:

Low Pressure: Recommend to be installed with a FloBOOST shower mixer.

Unequal Low Pressure:

- Minimum hot water pressure (Only with a FloBOOST). 10Kpa (flow pressure)
- Minimum cold water pressure (Only with a FloBOOST). 200kpa (flow pressure)
- Maximum cold water pressure. 500kpa

Equal Pressure - Low & Mains:

- Minimum water pressure. 20kpa (flow Pressure)
- Maximum Water pressure. 500kpa

- Pressure over 500kpa will require a limiting valve.
- Installation shall be in accordance with the AS/NZS3500 series of standards.

Distributed by: Greens Global Limited

PO Box 5055, Hamilton, 3200
22 The Boulevard, Te Rapa, Hamilton 3200
Phone: 07 849 0109, Fax: 07 849 0540
Website: www.greenstapware.com
Email: nzsales@greenstapware.com
Service Hotline: 0800 655 455

INSTALLATION INSTRUCTIONS

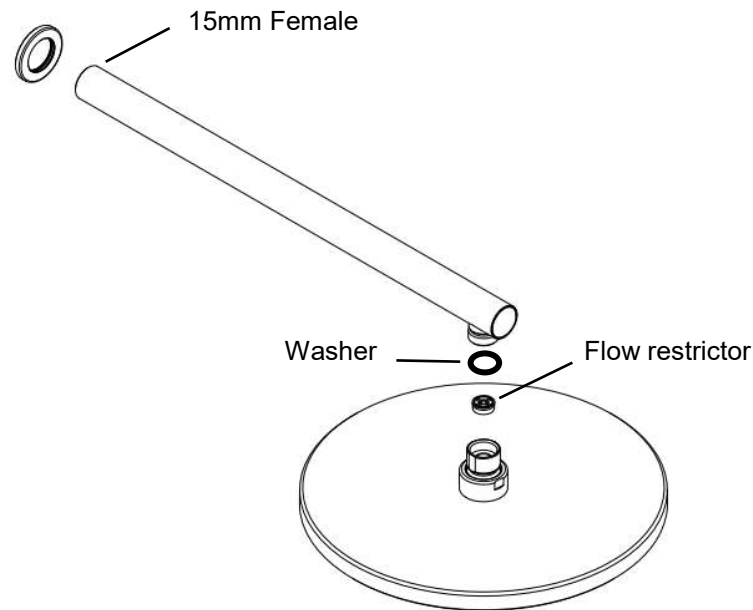

1. Position trim ring over the wall arm and remove the protective tape from seal on trim ring.
2. Install shower arm to 15mm male parallel thread (not supplied) and position the trim ring against the wall lining.
 - a. Max 15mm thread from finished wall.
 - b. Additional sealant maybe required for uneven surfaces.
3. Install overhead to arm and ensure washer seal is in place.

WELS – Mains pressure only

To achieve the 3 star 9.0 l/m rating install the WELS 3 star restrictor.

1. Remove the overhead rose from arm by unscrewing anti-clockwise.
2. Remove the washer seal in rose head .
3. Install the restrictor inside as shown above.
 - a. Will only go in one way, the narrow end first.
4. Replace washer seal and install rose head back onto the arm.



GLIDE RainBoost® OVERHEAD WALL SHOWER

(All Pressure Installations)
INSTALLATION INSTRUCTIONS

PRODUCT #
573009

BATCH #
120820

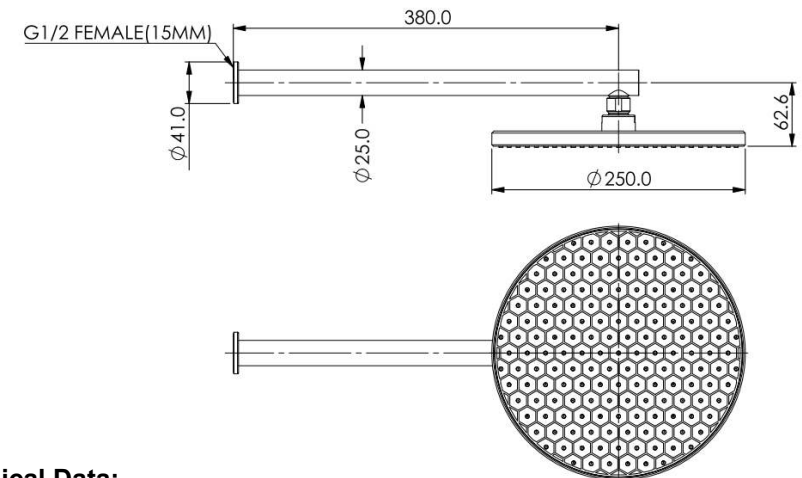

Technical Data:

Low Pressure: Recommend to be installed with a FloBOOST shower mixer.
Unequal Low Pressure:

- Minimum **hot** water pressure (Only with a FloBOOST). 10Kpa (flow pressure)
- Minimum **cold** water pressure (Only with a FloBOOST). 200kpa (flow pressure)
- Maximum cold water pressure. 500kpa

Equal Pressure - Low & Mains:

- Minimum water pressure. 20kpa (flow Pressure)
- Maximum Water pressure. 500kpa

- Pressure over 500kpa will require a limiting valve.
- Installation shall be in accordance with the AS/NZS3500 series of standards.

Distributed by: Greens Global Limited

PO Box 5055, Hamilton, 3200
22 The Boulevard, Te Rapa, Hamilton 3200
Phone: 07 849 0109, Fax: 07 849 0540
Website: www.greenstapware.com
Email: nzsales@greenstapware.com
Service Hotline: 0800 655 455