



VANTAGE SHOWER MIXER (For Mains Pressure Installations Only) INSTALLATION INSTRUCTIONS

PRODUCT #

BATCH #

ATTENTION PLUMBER

To ensure the optimum performance and customer satisfaction please adhere to the following:

- Flush out all pipe work prior to installation.
- Installation shall be in accordance with the AS/NZS3500 series of standards.
The maximum operating pressure within any building should not exceed 500kpa.
Pressure above 500kpa can cause damage from water hammer, reducing life of appliances, taps and fittings and cause excessive noise in the plumbing system.
- Pressure over 500kPa will require a limiting valve.
- Inline filters must be installed on both hot and cold supplies.

TECHNICAL DATA

- Suitable for use with high pressure water supply only.
- Minimum Water pressure for satisfactory operation: 150kPa
- Maximum Water pressure: 500kPa
- Maximum hot water temperature: 70°C
If the Water temperature exceeds 70°C an approved Tempering Valve must be fitted.

Please leave this form with the product once installed.

For full warranty terms and conditions, please see the warranty card enclosed with this product or visit www.greenstapware.com/warranty-and-care/

Distributed by: Greens Global Limited
PO Box 5055, Hamilton, 3200
22 The Boulevard, Te Rapa, Hamilton 3200
Phone: 07 849 0109, Fax: 07 849 0540
Website: www.greenstapware.com
Email: nzsales@greenstapware.com
Service Hotline: 0800 655 455

INSTALLATION INSTRUCTIONS SHOWER MIXER

Note: The Mixer can be mounted 39-75mm behind finished wall surface. Locate the correct position of the mixer by ensuring the “Hot” (H) inlet, enters from the left, when the outlet to the shower is at the top.

1. Position the mixer against a mounting board within the maximum and minimum depth allowed and fix.
2. Connect water supply to the mixer and from the mixer to the shower outlet.
 - a. **Do not pressure test with valve in the open position when the outlet is closed .**
 - b. Turn on water supply to the mixer and **check for leaks.**
3. Cut out an access hole in the wall lining for the mixer, as per drawing, and fix lining in place.
4. To secure the faceplate to the wall, remove the protective tape from the seal and slide the faceplate over the mixer body and position against the wall lining.
 - a. Drain hole in plate at the bottom .
 - b. Sealant will be required behind faceplate on uneven surfaces for water seal.
5. Install the handle onto the cartridge lever and tighten the screw under the handle and fit button.

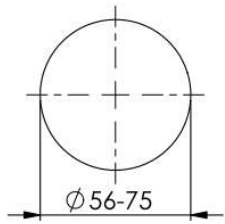
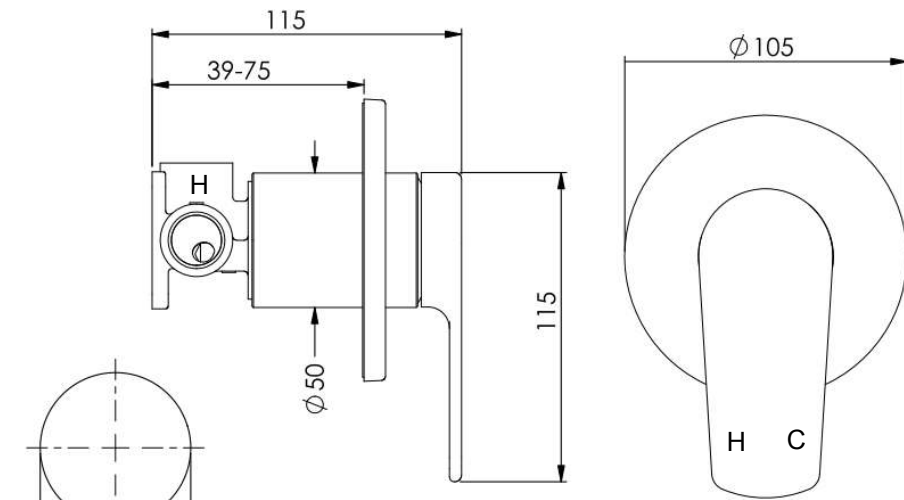

Mounting Hole

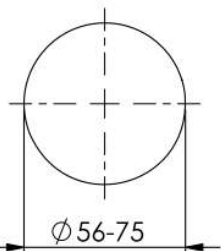
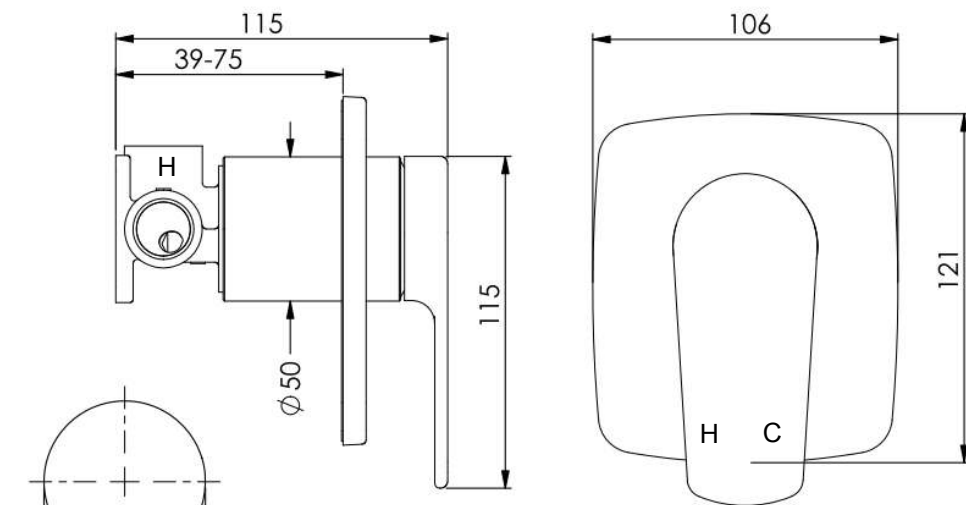

Mounting Hole