

BENCH TOPS

- ◆ Formica/wooden bench tops, extra mounting support is required below the bench.
- ◆ Stainless steel bench tops ensure the mounting washer is against the S/Steel.
- ◆ **Vitreous china tops additional sealant maybe required at the base of the mixer to ensure a water tight seal.**



GALIANO KONTACT[®] PULL DOWN SINK MIXER

(For Mains Pressure Installations Only)

MIXER INSTALLATION INSTRUCTIONS

PRODUCT #

BATCH #

Note:

- All pipework **MUST** be thoroughly **FLUSHED** prior to installation.
- **Maximum Bench thickness of 55mm.**
- Cut a mounting hole of **35mm in diameter** in the bench surface.

1. Unscrew mounting nut (3) and remove washers (1&2) from threaded mixer tail.
 - a. Ensure seal is sitting in groove at base of mixer
2. Lower mixer into bench top and position in top.
 - a. **Do not damage sensor wire.**
3. Install washers and mounting nut (See drawing in middle of leaflet).
 - a. Rubber washer (1) then plastic washer (2) over the mounting thread.
 - i. **DO NOT TIGHTEN SCREWS** until after the mounting nut has been tightened.
 - b. **Tighten the mounting nut (3) with tool supplied.**
 - c. **Tighten the 2 screws** on the **plastic washer (2).**
4. Install inlet hoses:
 - a. lightly grease the inlet O-rings with approved plumbing grease. (Not supplied.)
 - b. Screw the "Hot" hose (red) and **hand tighten** into the hot inlet of mixer.
 - c. Screw the "Cold" hose (blue) and **hand tighten** into the cold inlet of mixer.
5. Connect inlet hoses to water supply:
 - a. The union nuts must be connected to 15mm thread fittings which have a **machined end face with a chamfer, not "sawn off" threaded tube.**
 - b. **Do not over tighten the nuts.**
 - i. Hand tighten then 1/4 turn with spanner.
 - c. **Do not kink, stretch or twist**, any bends in the flexible hose should have a radius of no less than 85mm.
6. Install hand piece and weight.
 - a. Check hand piece has been hand tightened to hose (washer seal).
 - b. Install counter weight to hose and secure with the 2 screws.
7. **Check travel of handset** and reposition counter weight if necessary.
 - a. Inlet pipes do not foul the travel of the hose.
 - b. **Hose and weight movement is free**, the hose hangs in a loop and is not twisted.

ATTENTION PLUMBER

To ensure the optimum performance and customer satisfaction please adhere to the following:

- **Flush out all pipe work prior to installation.**
- Installation shall be in accordance with the AS/NZS3500 series of standards.

The maximum operating pressure within any building should not exceed 500kpa. Pressure above 500kpa can cause damage from water hammer, reducing life of appliances, taps and fittings and cause excessive noise in the plumbing system.
- Pressure over 500kPa will require a limiting valve.
- Inline strainer / filter must be installed in the line before the mixer to cover both hot and cold supplies (not supplied). Must be accessible.

TECHNICAL DATA

- **Suitable for use with high pressure water supply only.**
Not suitable for gravity-fed water heaters, low and unequal pressure networks
- Minimum Water pressure for satisfactory operation: 150kPa
- Maximum Water pressure: 500KPa
- Maximum hot water temperature: 70°C
If the Water temperature exceeds 70°C an approved Tempering Valve must be fitted.

WELS

- The flow rate of this product is rated under the NZ & Australian Water Efficiency Labeling Scheme (WELS) to 5 Star — 6.0 litres per minute.

Please leave this form with the product once installed.

For full warranty terms and conditions, please see the warranty card enclosed with this product or visit www.greenstapware.com/warranty-and-care/

Please contact country of purchase.

Distributed by: Greens Global Limited

PO Box 5055, Hamilton, 3200
22 The Boulevard, Te Rapa, Hamilton 3200
Phone: 07 849 0109, Fax: 07 849 0540
Website: www.greenstapware.com
Email: nzsales@greenstapware.com
Service Hotline: 0800 655 455

Distributed by: Greens Global AUS PTY LTD

36 Naxos Way, Keysborough VIC 3173
Phone: 1800 244 487 Fax: 1800 244 212
Email: aussales@greenstapware.com
Website: www.greenstapware.com
Service Hotline: 1800 244 992

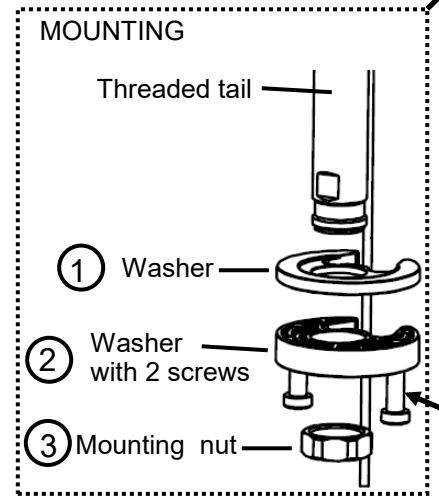
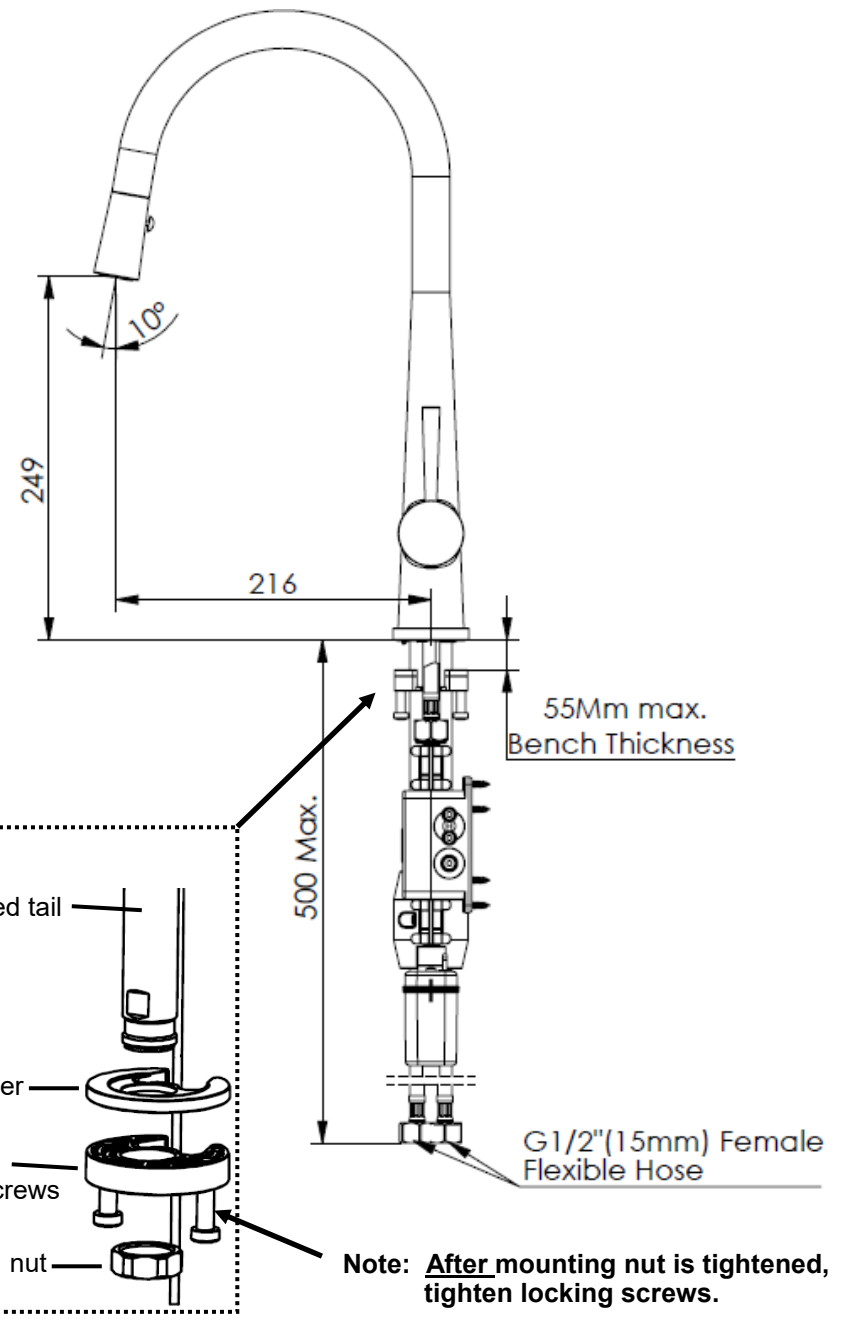
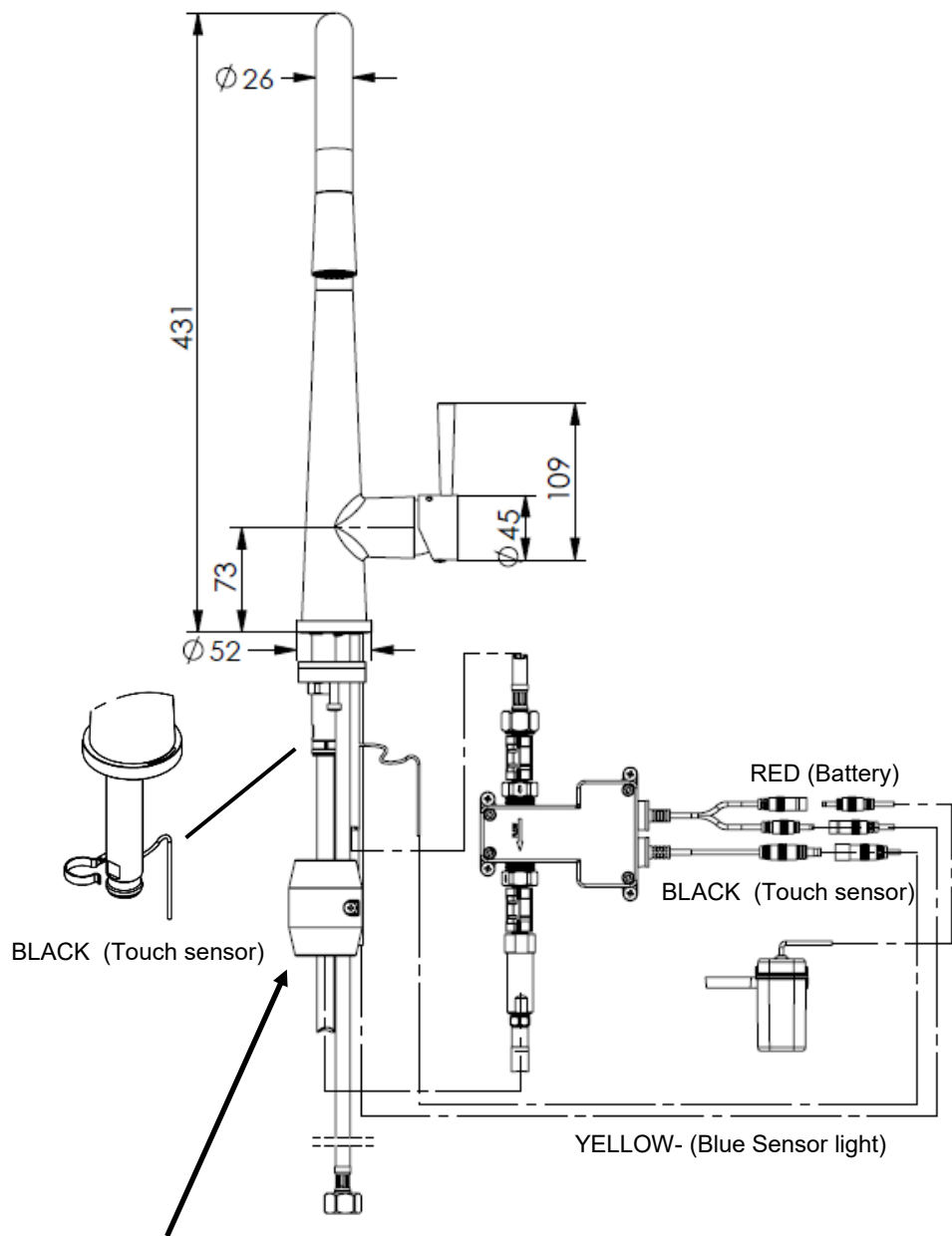

FULL INSTRUCTION SEE BACK OF LEAFLET