

1. Unscrew mounting nut and remove steel washer and rubber washer from threaded mixer tail. Ensure seal is sitting in groove at base of mixer
2. Lower mixer into bench top with hose.
3. From under bench install **rubber washer**, then **steel washer** and **mounting nut** up hose and screw onto threaded tail of mixer. Position mixer and tighten the jacking screws.
 - a. Screws may require backing off before installing nut.
4. Install inlet hoses:
 - a. lightly grease the inlet O-rings with approved plumbing grease. (Not supplied.)
 - b. Screw the "Hot" hose (red) and **hand tighten** into the hot inlet (red) of mixer.
 - c. Screw the "Cold" hose (blue) and **hand tighten** into the cold inlet of mixer.
5. Connect inlet hoses to water supply.
 - a. The union nuts must be connected to 15mm thread fittings which have a **machined end face with a chamfer, not "sawn off" threaded tube.**
 - b. **Do not over tighten the nuts.**
 - i. Hand tighten then 1/4 turn with spanner.
 - c. **Do not kink, stretch or twist**, any bends in the flexible hose should have a radius of no less than 85mm.
6. Connect the pull-down hose to the mixer outlet.
 - a. Check both the hose and brass connector are both tight to double check valve assembly.
 - b. Remove the grey quick fitting clip from the check valve assembly and make the connection to the mixer outlet and **secure with the quick fitting hose clip.**
7. Install counter weight.
 - a. Install counter weight to hose (see drawing) and secure with the 2 screws.
 - b. **Weight position is to be fitted on the vertical**, not at bottom of the loop.
8. **Check hand piece and hose movement.**
 - a. Inlet pipes do not foul the travel of the hose.
 - b. **Hose and weight movement is free**, the hose hangs in a loop and is not twisted.
 - c. Hand piece is hand tightened to hose.
9. Turn on water supply, **check for leaks**, **flow** and check the operation of the hand piece.
 - a. If low flow check filter is clean.

Please contact country of purchase.

Australia:
Distributed by: Greens Global (Australia) Ltd
 10/101 Wedgewood Rd, Hallam, Victoria 3803
 Phone: 1800 244 487 Fax: 1800 244 212
 Email: aussales@greenstapware.com
 Website: www.greenstapware.com
Service Hotline: 1800 244 992

NZ
Distributed by: Greens Global Limited
 PO Box 5055, Hamilton, 3200
 22 The Boulevard, Te Rapa, Hamilton 3200
 Phone: 07 849 0109, Fax: 07 849 0540
 Website: www.greenstapware.com
 Email: nzsales@greenstapware.com
Service Hotline: 0800 655 455



ASTRO II PULL DOWN SINK MIXER

(For Mains Pressure Installations Only)
INSTALLATION INSTRUCTIONS

PRODUCT #

BATCH #

ATTENTION PLUMBER

To ensure the optimum performance and customer satisfaction please adhere to the following:

- **Flush out all pipe work** prior to installation.
- Installation shall be in accordance with the AS/NZS3500 series of standards.
The maximum operating pressure within any building should not exceed 500kpa.
 Pressure above 500kpa can cause damage from water hammer, reducing life of appliances, taps and fittings and cause excessive noise in the plumbing system.
- Pressure over 500kPa will require a limiting valve.
- Inline strainer / filter must be installed before the hot and cold supplies (not supplied).
Note: Filter fitted at double check valve assembly (refer drawing inside).

TECHNICAL DATA

- **Suitable for use with high pressure water supply only.**
 Not suitable for gravity-fed water heaters, low and unequal pressure networks.
- Minimum Water pressure for satisfactory operation: 150kPa
- Maximum Water pressure: 500KPa
- Maximum hot water temperature: 70°C
 If the Water temperature exceeds 70°C an approved Tempering Valve must be fitted.

WELS

- The flow rate of this product is rated under the Australian & NZ Water Efficiency Labeling Scheme (WELS) to 5 Star — 6.0 litres per minute.

Please leave this form with the product once installed.

For full warranty terms and conditions, please see the warranty card enclosed with this product or visit www.greenstapware.com/warranty-and-care/

IMPORTANT: Outlet connection - Push fit with hose clip.

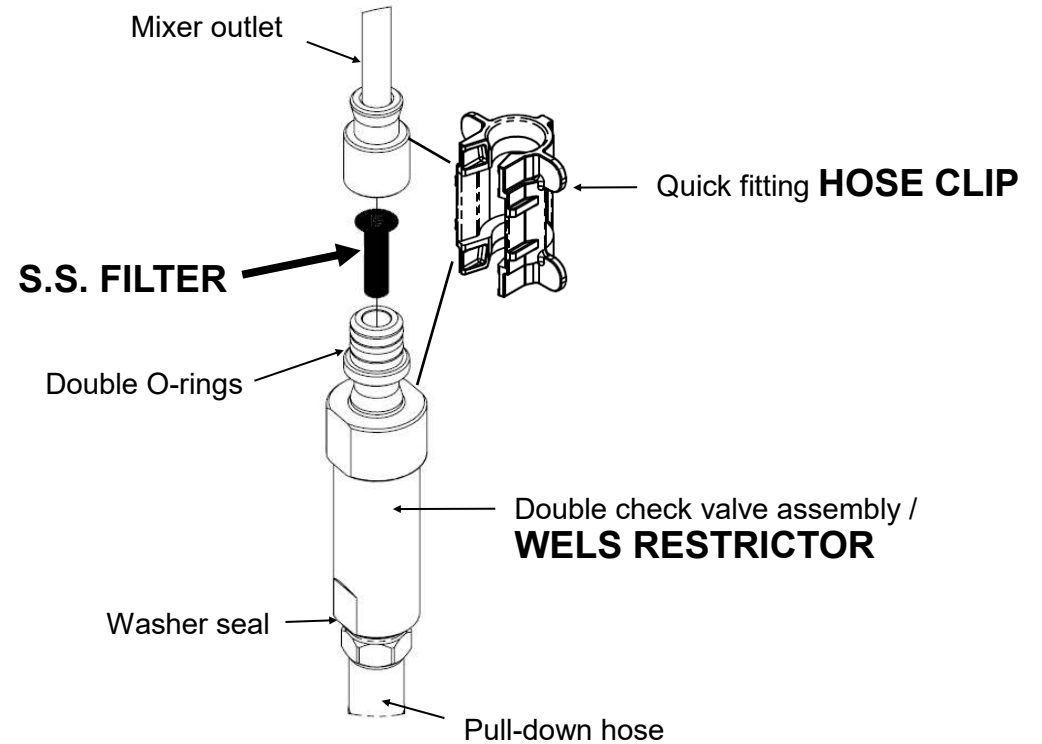
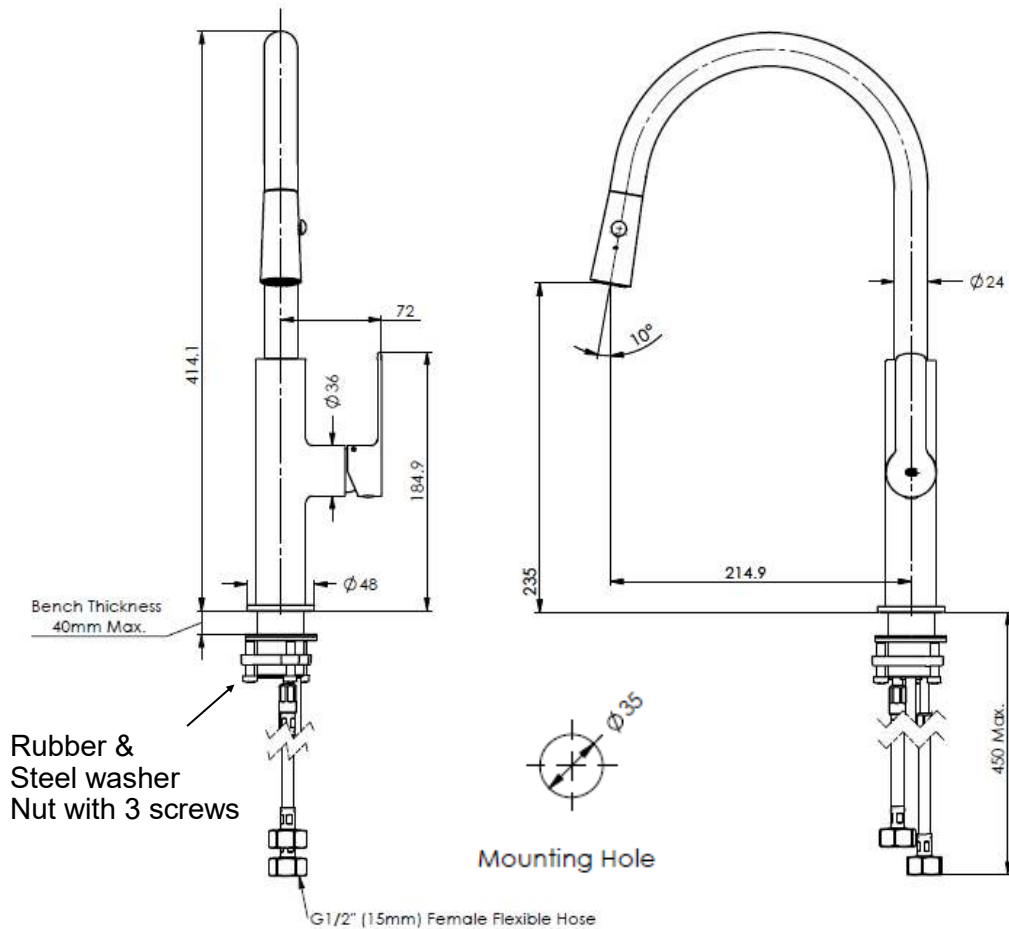

Rubber & Steel washer
Nut with 3 screws

Mounting Hole

G1/2" (15mm) Female Flexible Hose

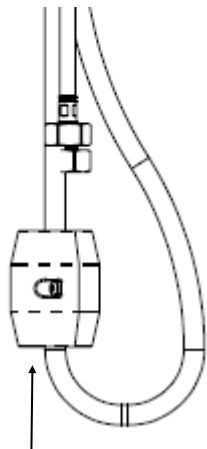

NOTE: Weight position **MUST** be on the vertical

NOTE:

- All pipework **MUST** be thoroughly **FLUSHED** prior to installation.
- **FILTER FITTED** at assembly inlet (Refer drawing above).
 - a. Protects the WELS restrictor as acts as a filter.
 - b. **If low flow check filter is clean.**
- Maximum Bench thickness of 40mm.
- Cut a mounting hole of 35mm in diameter in the bench surface.

FULL INSTRUCTION SEE BACK OF LEAFLET

BENCH TOPS

- ◆ Formica/wooden bench tops, extra mounting support is required below the bench.
- ◆ Stainless steel bench tops ensure the mounting washer is against the S/Steel.