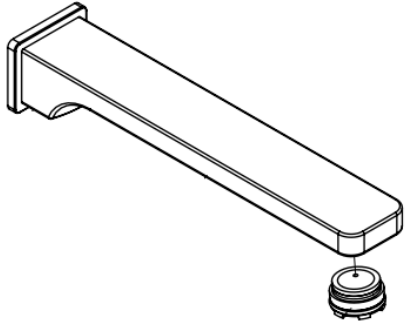

Removing Aerator:

To clean aerator at outlet, remove by turn anti-clockwise using tool supplied.

Bath Installations:

Remove the aerator and replace with the non WELS aerator using tool supplied.

**Anti-Scald Ring:**

An anti-scald ring is fitted to this mixer to limit the maximum movement of the handle when turned to the "HOT" position.



SWEPT WALL BASIN / BATH MIXER

(For Mains Pressure Installations Only)

INSTALLATION INSTRUCTIONS

PRODUCT #

BATCH #

ATTENTION PLUMBER

To ensure the optimum performance and customer satisfaction please adhere to the following:

- Flush out all pipe work prior to installation
- Installation shall be in accordance with the AS/NZS3500 series of standards.
The maximum operating pressure within any building should not exceed 500kpa.
Pressure above 500kpa can cause damage from water hammer, reducing life of appliances, taps and fittings and cause excessive noise in the plumbing system.
- Pressure over 500kPa will require a limiting valve.
- Inline filters must be installed on both hot and cold supplies.

TECHNICAL DATA

- Minimum Water pressure for satisfactory operation: 150kPa
- Maximum Water pressure: 500kPa
- Maximum hot water temperature: 70°C
If the Water temperature exceeds 70°C an approved Tempering Valve must be fitted.
- The flow rate of the sink and basin mixers has been rated under the NZ Water Efficiency Labeling Scheme (WELS).

Please leave this form with the product once installed.

For full warranty terms and conditions, please see the warranty card enclosed with this product or visit www.greenstapware.com/warranty-and-care/

Distributed by: Greens Global Limited

PO Box 5055, Hamilton, 3200

22 The Boulevard, Te Rapa, Hamilton 3200

Phone: 07 849 0109, Fax: 07 849 0540

Website: www.greenstapware.com

Email: nzsales@greenstapware.com

Service Hotline: 0800 655 455

#40032 07/18

INSTALLATION INSTRUCTIONS

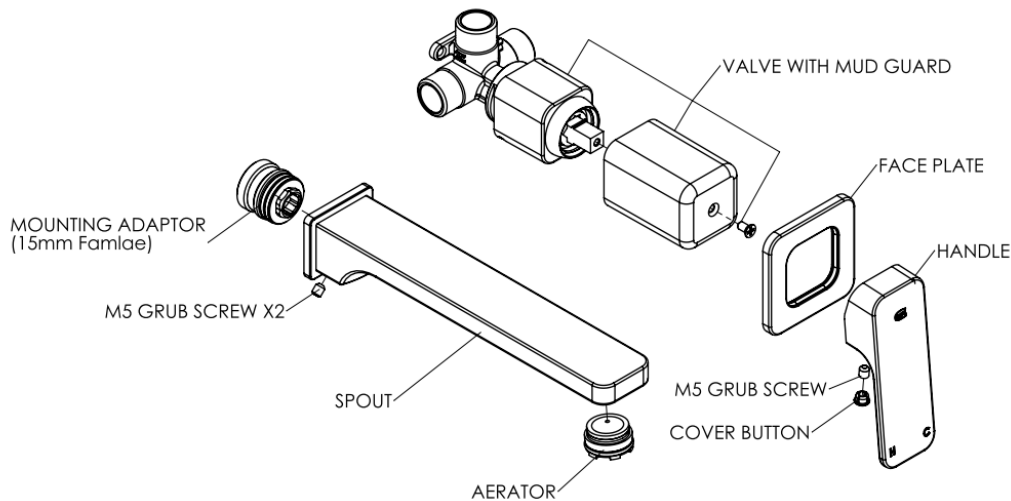
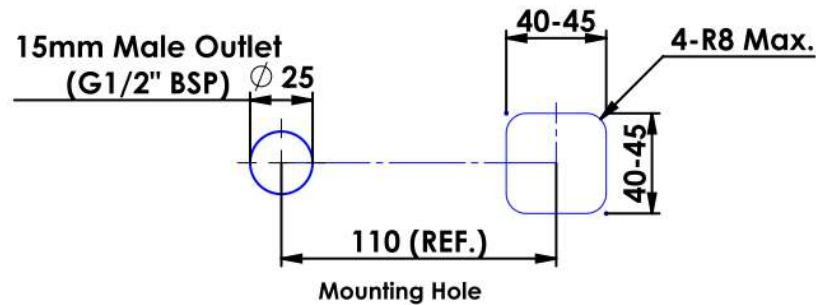
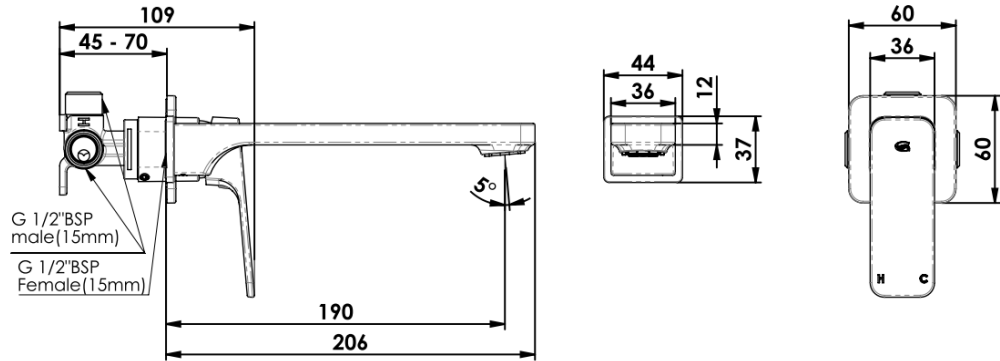

Note: Cut out holes in finished walls. Valve 40 X 45mm square. Spout 25mm. Valve mounting 45-70mm behind finished wall.

Installing Mixer Valve Body:

- Position the mixer against a mounting board within the **maximum and minimum depth of 45-70mm** and fix.
 - Ensure the "Hot" (H) inlet, enters from the left, when the outlet to the shower is at the top.
 - Mug guard has minimum and maximum for finished wall.
 - Leave mud guard on valve body until final fit out.
 - Note: Finished wall cut out must be up to the mud guard.**
 - Note: Maximum cut out of 40 x 45mm square.**
- Connect water supply to the mixer and from the mixer to the shower outlet.
 - Do not pressure test with valve in the open position when the outlet is closed.**

Installing Bracket Elbow For Spout (not supplied):

- Install a brass 15mm male wingback elbow for spout position and connect water supply from mixer outlet to elbow.
 - Min 80mm from mixer to spout. Drawing 110mm (REF) is for guide only.
 - Check alignment of body and wall elbow.**
 - Note: Must have **MAX 15mm of thread** from finished wall for adaptor.
- Plug off elbow for water test.
- Turn on water supply on and check for leaks.

Install Face Plate & Handle:

- Remove the mud guard by removing screw.
- Remove the protective tape from the seal and slide the faceplate over the mixer body and position against the wall lining.
 - Ensure the drain hole in plate at the bottom
- Sealant will be required behind faceplate on uneven surfaces for water seal.
- Install the handle onto the cartridge lever and tighten the screw under the handle with the 2.5mm Allen key supplied and fit button.

Installing Spout & Mounting Adaptor:

- Cut out mounting hole in finished wall for **spout 25mm** as per drawing.
- Cut inlet thread to length,
 - MAX 15mm thread from finished wall.**
- Remove the mounting adaptor from spout by unscrewing the grub screws under the spout until nearly out.
 - This is to ensure the O-rings on the adaptor are not cut.
- Install the female mounting adaptor.
 - Use a spanner or 10mm Allen key.
- Grease O-rings, install spout ensuring seal is in place and tighten grub screws.