

INSTALLATION INSTRUCTIONS

Note: Mounting hole in finished wall MAX 25mm.

Install Wall Bracket:

- Carefully position trim ring to wall bracket.
 - Grease seal inside trim for ease of install.
- Install the wall bracket to 15mm parallel thread (thread not supplied) and position trim ring against the finished wall.
 - Cut the inlet thread, to a **MIN of 10mm / MAX 15mm thread** from finished wall.
 - NOTE: Sealant is required behind flange** for a water tight seal.
(Not supplied.)

Installing Hose And Handset:

- Connect nut end of hose to wall bracket elbow outlet and ensure the sealing washer is in place and lightly nip up with a spanner.
- Hand tighten handset to tapered end of hose and ensure seal washer is in place.

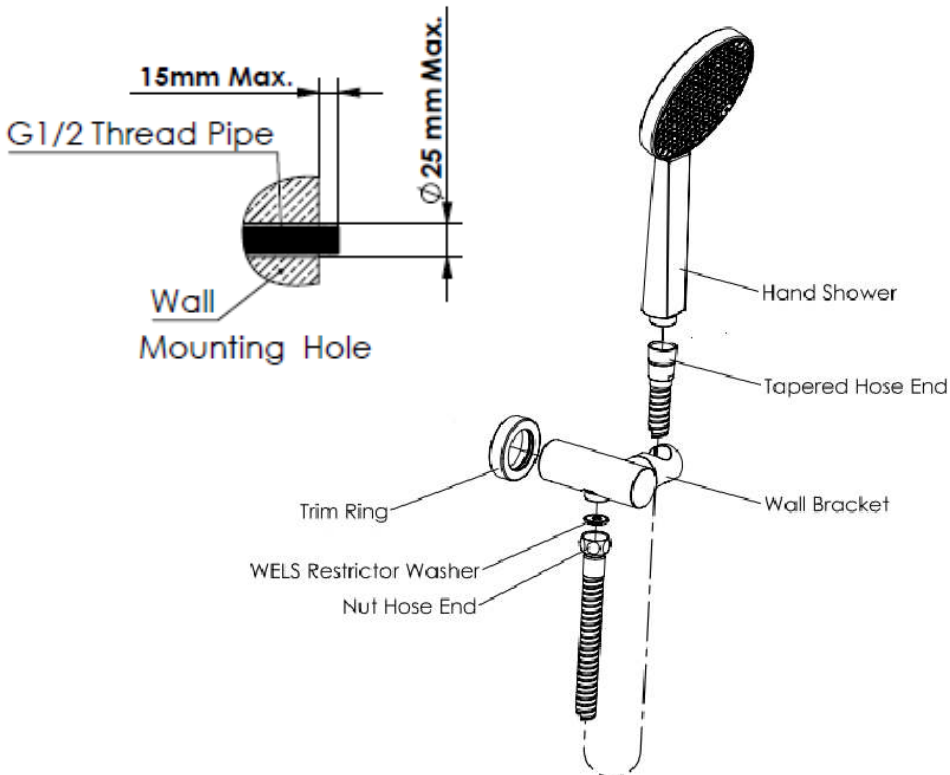

HAND SHOWER WITH WALL OUTLET BRACKET

(Mains pressure Installations Only)

INSTALLATION INSTRUCTIONS

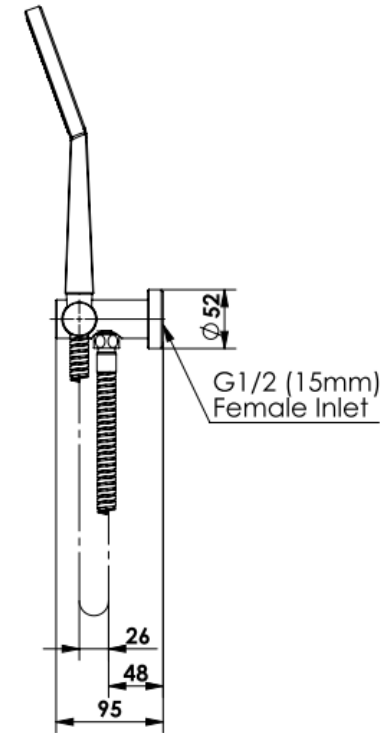

Technical Data

- Suitable for use with high pressure water supply only.**
Not suitable for gravity-fed water heaters, low and unequal pressure networks.
- Minimum Water pressure: 150kpa.
- Maximum water pressure: 500kpa
- Pressure over 500kpa will require a limiting valve.
- Flush out all pipe work prior to installation.**
- Installation shall be in accordance with the AS/NZS3500 series of standards.
- Flow rate of 3 star 9 l/m has been rated under the NZ & Australian Water Efficiency Labeling Scheme (WELS).

Distributed by: Greens Global Limited
PO Box 5055, Hamilton, 3200
22 The Boulevard, Te Rapa, Hamilton 3200
Phone: 07 849 0109, Fax: 07 849 0540
Website: www.greenstapware.com
Email: nzsales@greenstapware.com
Service Hotline: 0800 655 455

Distributed by: Greens Global (Australia) Ltd
10/101 Wedgewood Rd, Hallam, Victoria 3803
Phone: 1800 244 487 Fax: 1800 244 212
Email: aussales@greenstapware.com
Website: www.greenstapware.com
Service Hotline: 1800 244 992

INSTALLATION INSTRUCTIONS

Note: Mounting hole in finished wall MAX 25mm.

Install Wall Bracket:

- Carefully position trim ring to wall bracket.
 - Grease seal inside trim for ease of install.
- Install the wall bracket to 15mm parallel thread (thread not supplied) and position trim ring against the finished wall.
 - Cut the inlet thread, to a **MIN of 10mm / MAX 15mm thread** from finished wall.
 - NOTE: Sealant is required behind flange** for a water tight seal. (Not supplied.)

Installing Hose And Handset:

- Connect nut end of hose to wall bracket elbow outlet and ensure the sealing washer is in place and lightly nip up with a spanner.
- Hand tighten handset to tapered end of hose and ensure seal washer is in place.

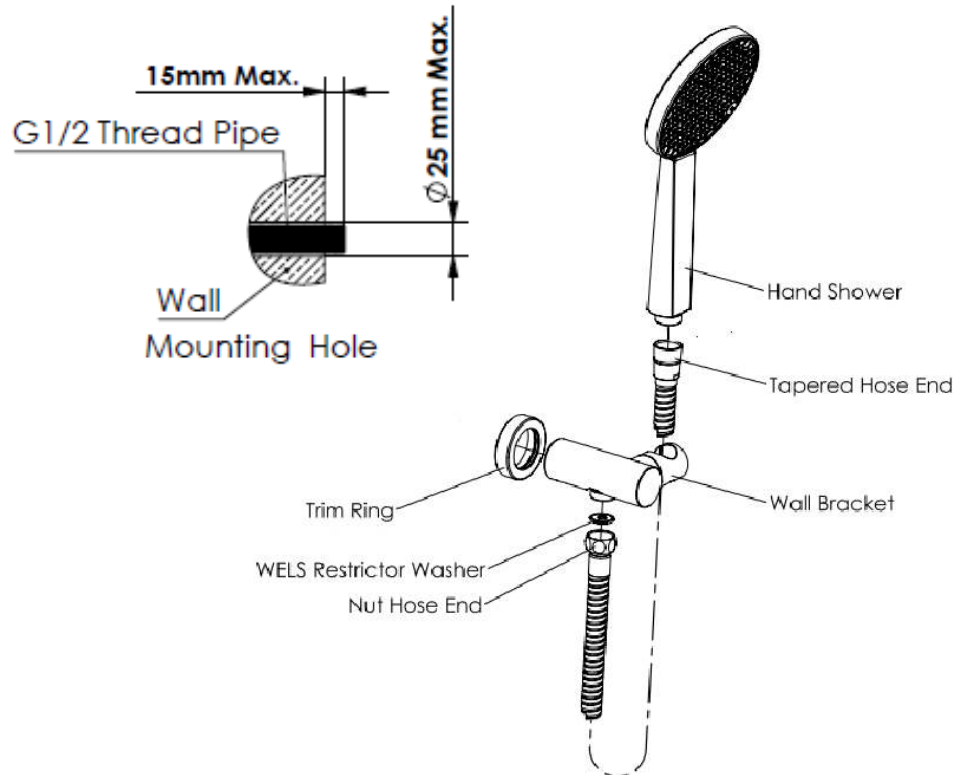

HAND SHOWER WITH WALL OUTLET BRACKET

(Mains pressure Installations Only)
INSTALLATION INSTRUCTIONS

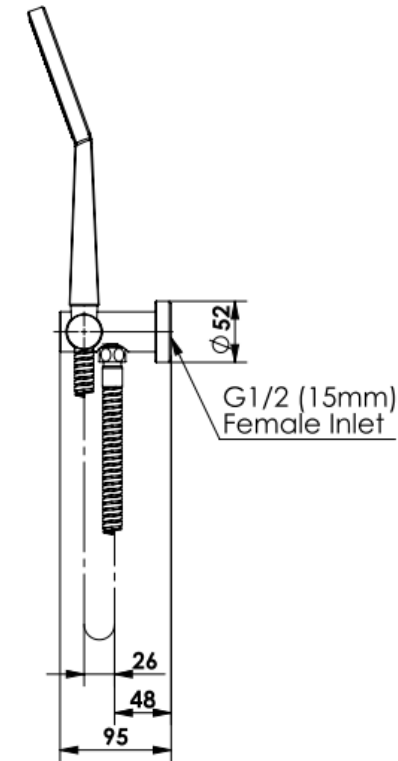

Technical Data

- Suitable for use with high pressure water supply only.**
Not suitable for gravity-fed water heaters, low and unequal pressure networks.
- Minimum Water pressure: 150kpa.
- Maximum water pressure: 500kpa
- Pressure over 500kpa will require a limiting valve.
- Flush out all pipe work prior to installation.**
- Installation shall be in accordance with the AS/NZS3500 series of standards.
- Flow rate of 3 star 9 l/m has been rated under the NZ & Australian Water Efficiency Labeling Scheme (WELS).

Distributed by: Greens Global Limited
PO Box 5055, Hamilton, 3200
22 The Boulevard, Te Rapa, Hamilton 3200
Phone: 07 849 0109, Fax: 07 849 0540
Website: www.greenstapware.com
Email: nzsales@greenstapware.com
Service Hotline: 0800 655 455

Distributed by: Greens Global (Australia) Ltd
10/101 Wedgewood Rd, Hallam, Victoria 3803
Phone: 1800 244 487 Fax: 1800 244 212
Email: aussales@greenstapware.com
Website: www.greenstapware.com
Service Hotline: 1800 244 992