

ADJUSTING FLOW LIMITER:

A flow limiter is fitted to this mixer to limit the flow of water in high pressure situations.

1. Remove handle by loosening grub screw through access hole under the handle button with a 2.5mm Allen key.
2. Turn mixer on full and wind in grub screw clockwise to achieve desired flow rate.
3. Replace handle.

ADJUSTING ANTI-SCALD RING:

An anti-scald ring is fitted to this mixer to limit the maximum movement of the handle when turned to the "HOT" position.

Ex factory the cartridge is set to the maximum HOT water flow.

1. Remove handle by loosening grub screw through access hole under the handle button with a 2.5mm Allen key. Unscrew cover sleeve.
2. Lift the red anti-scald ring sufficiently to disengage. Turn anti-clockwise and replace until the desired maximum temperature is obtained. Each notch on the ring gives a temperature change of approximately 2°C.
3. Replace cover sleeve and handle.



MARKETTI BLADE SHOWER MIXERS (For All Pressure Installations) INSTALLATION INSTRUCTIONS

PRODUCT #

BATCH #

ATTENTION PLUMBER

To ensure the optimum performance and customer satisfaction please adhere to the following:

- Flush out all pipe work prior to installation
- Installation shall be in accordance with the AS/NZS3500 series of standards.
The maximum operating pressure within any building should not exceed 500kpa.
Pressure above 500kpa can cause damage from water hammer, reducing life of appliances, taps and fittings and cause excessive noise in the plumbing system.
- Pressure over 1000kPa will require a limiting valve.
- Inline filters must be installed on both hot and cold supplies.

TECHNICAL DATA

- Minimum Water pressure for satisfactory operation: 20kPa
- Maximum Water pressure: 1000KPa
- Maximum hot water temperature: 70°C
If the Water temperature exceeds 70°C an approved Tempering Valve must be fitted.

Please leave this form with the product once installed.

For full warranty terms and conditions, please see the warranty card enclosed with this product or visit www.greenstapware.com/warranty-and-care/

Distributed by: Greens Global Limited

PO Box 5055, Hamilton, 3200
22 The Boulevard, Te Rapa, Hamilton 3200
Phone: 07 849 0109, Fax: 07 849 0540
Website: www.greenstapware.com
Email: nzsales@greenstapware.com
Service Hotline: 0800 655 455

Marketti Blade Shower Mixer

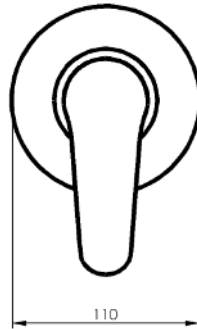
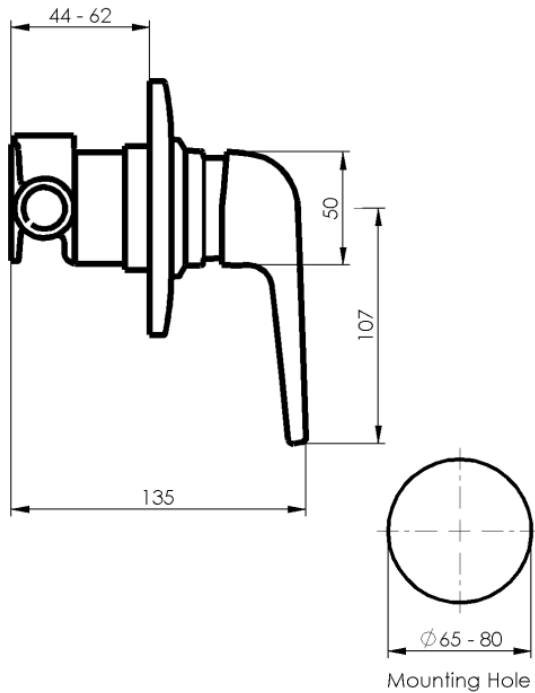

Marketti Sphere Shower Mixer

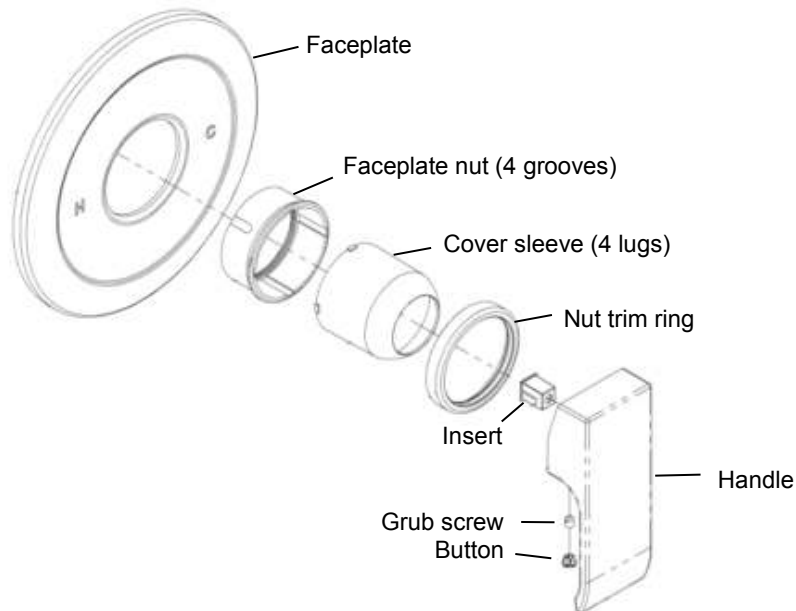
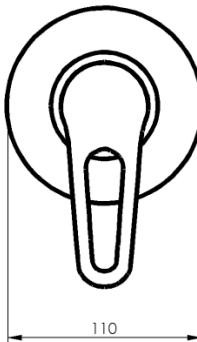

INSTALLATION INSTRUCTIONS SHOWER MIXER

Note: The Mixer can be mounted 44-62mm behind finished wall surface.

Locate the correct position of the mixer by ensuring the "Hot" inlet (H), enters from the left, when the outlet to the shower is at the top.

Note: Unequal pressure only install the adjustable flow limiter.

Installing Valve Body:

1. Remove the cover sleeve, white plastic nut and trim ring by gripping the cover sleeve and turning anti-clockwise.
2. Position the mixer against a mounting board within the maximum and minimum depth allowed and fix.
3. **Unequal Pressure Only: Install the adjustable flow limiter.**
 - a. To the mains cold water inlet, on right hand side of valve body.
 - b. Slotted **screw head** is to be **accessible** for adjustment purposes.
 - c. Do not install for equal pressure installations.
4. Connect water supply to the mixer and from the mixer to the shower outlet.
 - a. **Do not pressure test with valve in the open position when the outlet is closed.**
 - b. Turn on water supply to the mixer and **check for leaks.**
5. Cut out an access hole in the wall lining for the mixer, as per drawing and fix lining in place.

Install Trim Set:

1. For Unequal pressure, **adjust the flow regulator** before installing the face plate.
 - a. Adjust the volume of cold water to match the hot water.
 - b. The shower rose/slide shower must be installed before making adjustment.
2. Install the faceplate over valve body to the wall with "H" (hot) on the left.
3. Slide the cover sleeve inside the 4 grooves of the faceplate nut and install to the valve body using the cover sleeve as a tool and tighten.
 - a. Apply **grease to the O-ring** on the valve body for cover sleeve install.
 - b. Note: The edge of the faceplate nut holds the faceplate firm against the finished wall.
 - c. Sealant will be required behind faceplate on uneven surfaces for water seal.
4. Slide the nut trim cover over cover sleeve and against the faceplate.
5. Install the handle onto the cartridge lever and tighten the screw under the handle and fit button.