

Install Trim Set:

1. Cut out an access hole in the wall lining for the mixer, 52-70mm as per drawing and fix lining in place.
2. To secure the faceplate to the wall, remove the protective tape from the seal and slide the faceplate over the mixer body and position against the wall lining.
 - a. Ensure seal is in place on the inside of plate for valve body.
 - b. Gap in seal is at the bottom with H on the left and C on the right.
 - c. Sealant will be required behind faceplate on uneven surfaces for water seal.
3. Install the handle onto the cartridge lever and tighten the grub screw and fit button



ARCAS FloBOOST® SHOWER MIXER
(For All Pressure Installations)
INSTALLATION INSTRUCTIONS

PRODUCT #

BATCH #

Attention Plumber:

To ensure the optimum performance and customer satisfaction please adhere to the following:

Failure to comply with the below will void all warranties.

- **Flush out all pipe work prior to installation.**
- Installation to comply with Australian/New Zealand Water Standard AS/NZS 3500.1. The maximum operating pressure within any building should not exceed 500kpa. Pressure above 500kpa can cause damage from water hammer, reducing life of appliances taps and fittings and cause excessive noise in the plumbing system.
- **Pressure over 500kPa will require a limiting valve that must be installed.** Temperature performance on the FloBoost valve can be affected when over 500kpa.
- **Hot water temperature must be minimum 55°C.**
- **Inline strainer / filter** must be installed in the line before the mixer to cover both hot and cold supplies (not supplied). Must be accessible.

TECHNICAL DATA

Unequal pressure

- Minimum **hot** water pressure 10Kpa (flow)
- Minimum **cold** water pressure 200kPa (flow)
- Maximum Water pressure: **500kPa**

Equal pressure

- Minimum water pressure 20kpa (flow)
- Maximum Water pressure: 500kPa

Operating Temperature

- Minimum hot water temperature **55°C**
 - Maximum hot water temperature: 70°C
 - Minimum cold water temperature 5°C
- If the Water temperature exceeds 70°C an approved Tempering Valve must be fitted.

Please leave this form with the product once installed.

Distributed by: Greens Global Limited
PO Box 5055, Hamilton, 3200
22 The Boulevard, Te Rapa, Hamilton 3200
Phone: 07 849 0109, Fax: 07 849 0540
Website: www.greenstapware.com
Email: nzsales@greenstapware.com
Service Hotline: 0800 655 455

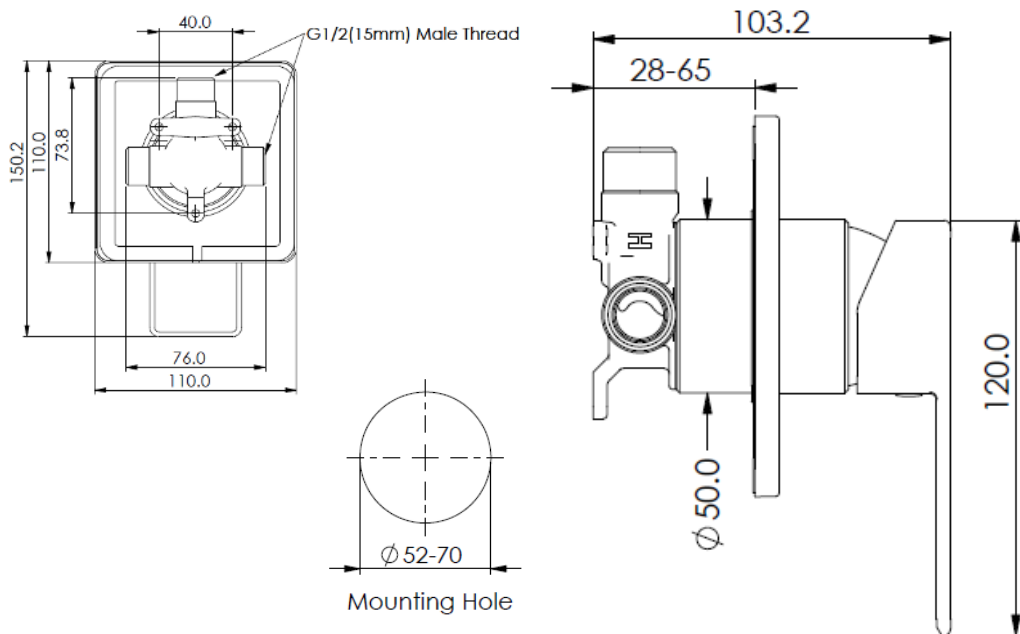

CHECK: Jet in body **MUST** fit inside the swivel nut connector

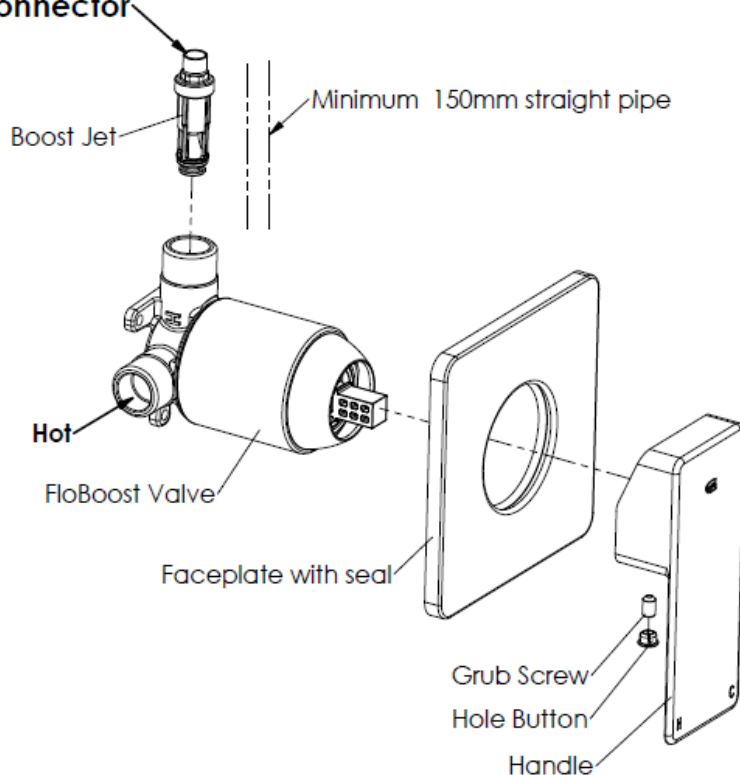

ATTENTION INSTALLER

- Greens FloBOOST® shower mixer is a Venturi mixer using the cold water pressure to maximise the hot water flow and is factory **set for UNEQUAL PRESSURE**.
 - Mains Cold goes through the boost jet at mixer outlet.

CHECK FIRST: Do you have EQUAL or UNEQUAL pressure **at the mixer?**

- EQUAL LOW PRESURE:** The FloBOOST® valve will perform best if can link a mains pressure cold feed to the cold inlet of the valve.
- EQUAL PRESSURE (LOW & MAINS):** The **JET MUST BE REMOVED**.
 - Anti-clockwise with a **10mm socket**.
 - Ensure the **ENTIRE JET IS REMOVED**.
- UNEQUAL PRESSURE:** Mixer is set up for unequal pressure.
- COLD WATER PRESSURE:** If **over 500Kpa** a limiting vale **must** be installed as this will effect the mixing operation.
- HOT TEMPERATURE:** Must be **minimum 55°C** at the mixer.
- RAIL SHOWERS:** Wide bore hose 10mm with a good single function handset for low pressure, with no restrictors. Greens RainBoost® shower range is recommended.

INSTALLATION INSTRUCTIONS

Installing Valve Body:

- Position the mixer against a mounting board within the maximum and minimum depth allowed and fix.
 - 28-65m** behind finished wall surface.
 - Hot (H) enters on the left and cold (C) enters on the right.**
 - Outlet to the top.
- UNEQUAL PRESSURE:**
 - Install minimum **150mm of STRAIGHT PIPE** from the mixer outlet.
 - CHECK: THE JET must FIT INSIDE the swivel nut connector.**
 - If it doesn't, an **M & F SOCKET must be installed to mixer outlet.**
 - This is to ensure the jet is not damaged and the mixer performance is not compromised.
- EQUAL PRESSURE:**
 - REMOVE JET** from the mixer outlet anti-clockwise with a **10mm socket**
- Connect water supply to the male hot & cold inlets and to the shower outlet. **Do not pressure test with valve in the open position when outlet is closed.** Turn on water supply to the mixer and check for leaks.