

WELS

On mains pressure systems to achieve the WELS star rating the aerator insert at the end of the spout needs to be replaced. Unscrew the aerator cone and replace aerator insert with the WELS rated aerator insert supplied.



EDGE MINI BASIN (For All Pressure Installations) INSTALLATION INSTRUCTIONS

PRODUCT #

BATCH #

ATTENTION PLUMBER

To ensure the optimum performance and customer satisfaction please adhere to the following:

- Flush out all pipe work prior to installation
- Installation shall be in accordance with the AS/NZS3500 series of standards.
The maximum operating pressure within any building should not exceed 500kpa.
Pressure above 500kpa can cause damage from water hammer, reducing life of appliances, taps and fittings and cause excessive noise in the plumbing system.
- Pressure over 500kPa will require a limiting valve.
- Inline filters must be installed on both hot and cold supplies.

TECHNICAL DATA

- Minimum Water pressure for satisfactory operation: 35KPa
- Maximum Water pressure: 500kPa
- Maximum hot water temperature: 70°C
If the Water temperature exceeds 70°C an approved Tempering Valve must be fitted.
- The flow rate of the sink and basin mixers has been rated under the NZ Water Efficiency Labeling Scheme (WELS).

Please leave this form with the product once installed.

For full warranty terms and conditions, please see the warranty card enclosed with this product or visit www.greenstapware.com/warranty-and-care/

Distributed by: Greens Global Limited

PO Box 5055, Hamilton, 3200
22 The Boulevard, Te Rapa, Hamilton 3200
Phone: 07 849 0109, Fax: 07 849 0540
Website: www.greenstapware.com
Email: nzsales@greenstapware.com
Service Hotline: 0800 655 455

#41519

07/17

INSTALLATION INSTRUCTIONS BASIN MIXER

BENCH TOPS

- ◆ Formica/wooden bench tops, extra mounting support is required below the bench.
- ◆ Stainless steel bench tops ensure the mounting washer is against the S/Steel.
- ◆ **Vitreous china tops additional sealant maybe required at the base of the mixer to ensure a water tight seal.**

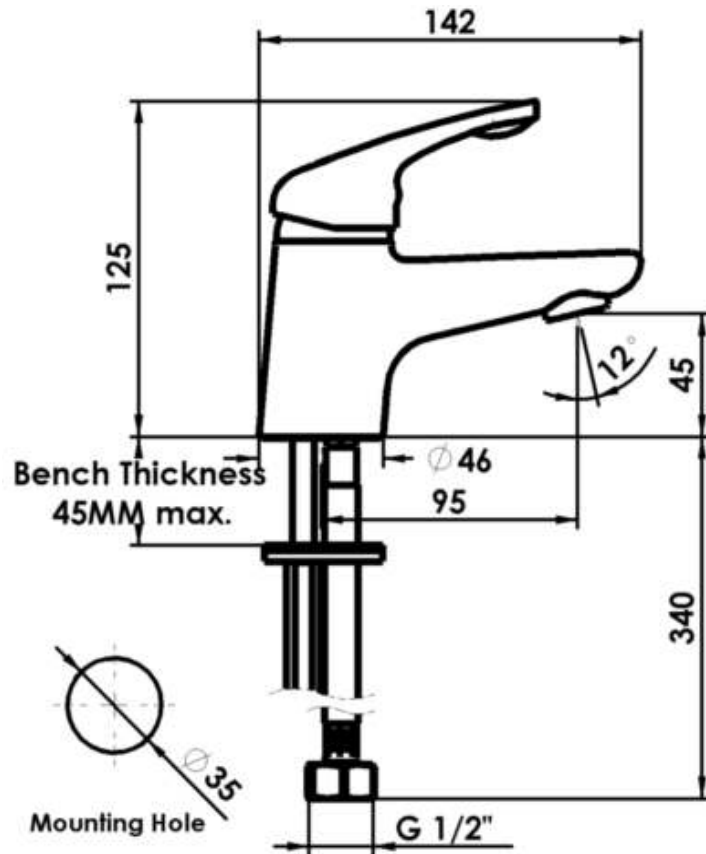

Note: Fits Maximum Bench thickness of 45mm.

To install mixer, cut a mounting **hole 35mm** in diameter in the bench surface.

Equal pressure Installations only: Please remove non-return valve pre fitted to "Hot" water inlet hose (red braided hose).

1. Screw the **M8 mounting thread** into base of mixer and **tighten**.
2. **Install seal** at base of mixer.
3. Screw the "Hot" hose (red) and **hand tighten**, into the left hand hose inlet (H) in the base of the mixer.
4. Lower fitted hose into the mounting hole and lay mixer on bench.
5. Feed the "Cold" hose (blue) through the mounting hole from **underneath the bench**. Pick up mixer and screw the hose and **hand tighten**, into cold inlet of mixer.
6. Position mixer in bench top with the **mounting thread to the rear**.
7. From under bench, install the **rubber washer** then the **steel washer** over mounting thread and screw the **mounting nut** to mounting thread.
Tighten with 11mm tube spanner and secure the mixer to the bench.
8. **Connect flexi hoses** to water supply.
 - a. Non-return valve must be fitted to hot inlet hose for unequal pressure (arrow for flow).
 - b. The union nuts must be connected to 15mm thread fittings which have a **machined end face with a chamfer, not "sawn off" threaded tube**.
 - c. **Do not over tighten the nuts**.
 - i. Hand tighten then 1/4 turn with spanner.
 - d. **Do not kink, stretch or twist**, any bends in the flexible hose should have radius of no less than 85mm.
9. Turn on water supply and **check for leaks**.